



American Earth Anchors

The best screw you will have in the dirt™

americaneearthanchors.com

QUICK REFERENCE

PE-T9 | Specifications

9" Penetrator® with T-handle

- Aircraft-quality cast aluminum 356 alloy
- Heat-treated to T6 specification
- Removable

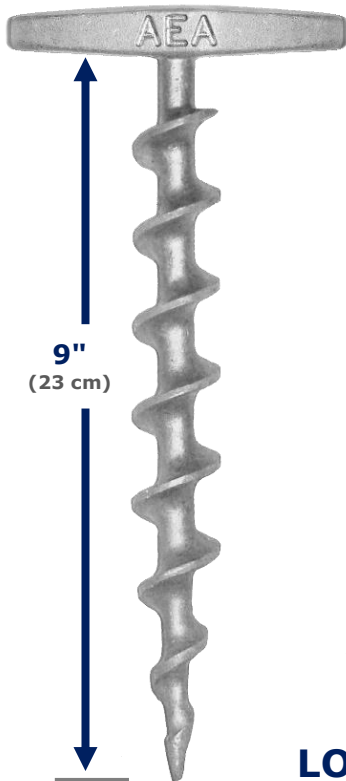
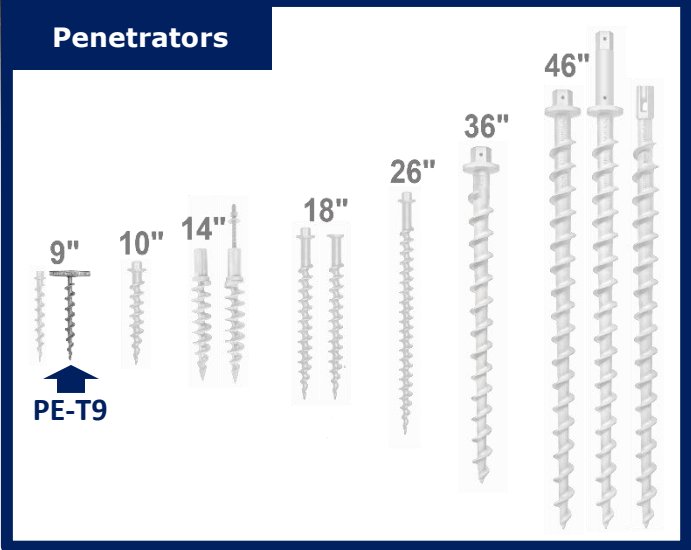

9"
(23 cm)

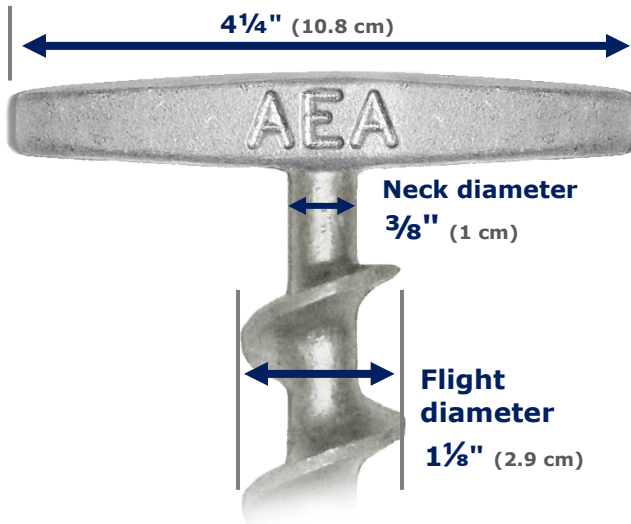

4 1/4" (10.8 cm)

Neck diameter
3/8" (1 cm)

Flight diameter
1 1/8" (2.9 cm)

LOAD CAPACITY

Pullout strength with flight fully embedded

Soil Class 1	Soil Class 2	Soil Class 3	Soil Class 4	Soil Class 4
Hardpan Asphalt	Sandy gravel Very dense sand	Silty/clayey sand Silty gravel	Loose/med dense sands Loose sands Firm clays	Loose fine un- compacted sand
400 lb 1.78 kN	200 lb 0.89 kN	100 lb 0.44 kN	Less than 100 lb 0.44 kN	Less than 100 lb 0.44 kN

Soil classification per ASTM D-2487/2488

© 2018 American Earth Anchors
QR-PE-T9 Mar 2018



American Earth Anchors
info@americanea.com
americaneearthanchors.com

Contact us for CUSTOM WORK
Size, length, shape, material,
prototypes, cable assemblies



866-520-8511

+1 508-520-8511

PE-T9 | Installation

Installation method



By hand

Attachment accessory

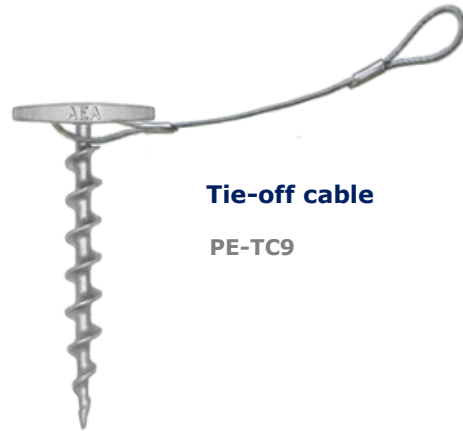

**Tie-off cable
PE-TC9**



Camp tent



Plant support



RV awning



Dog tie-out



Beach shelter



Pop-up tent

