



American Earth Anchors

The best screw you will have in the dirt™

americanearthanchors.com

QUICK REFERENCE

PE36 | Specifications

36" Penetrator™

- Aircraft-quality cast aluminum 356 alloy
- Heat-treated to T6 specification
- Install with 2" or 51 mm socket
- Removable/reusable

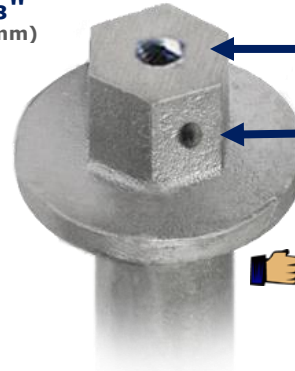
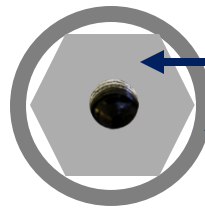
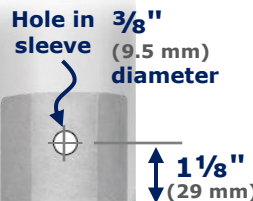
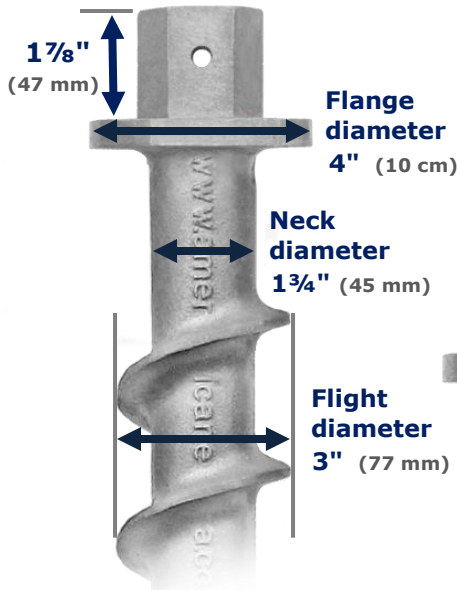

6-point socket (instead of 12-point socket) will minimize wear and rounding of hex head for repeated installation/removal

Penetrators

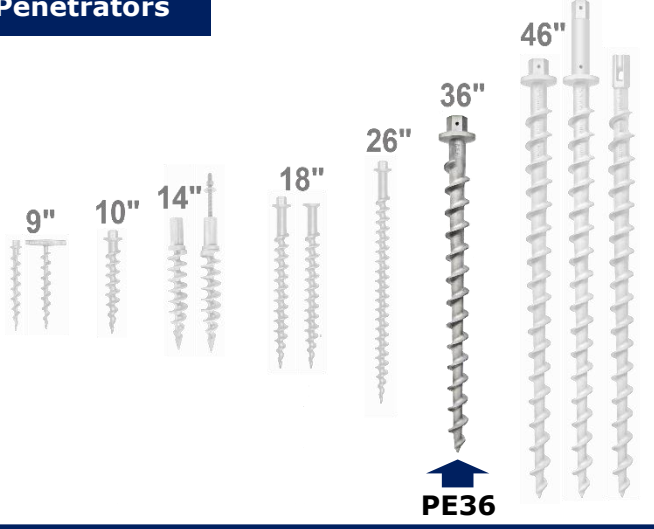

LOAD CAPACITY

Pullout strength with flight fully embedded

Soil Class 1	Soil Class 2	Soil Class 3	Soil Class 4	Soil Class 4
Hardpan Asphalt	Sandy gravel Very dense sand	Silty/clayey sand Silty gravel	Loose/med dense sands Loose sands Firm clays	Loose fine un- compacted sand
8,400 lb 37.4 kN	6,000 lb 26.7 kN	2,100 lb 9.34 kN	1,000 lb 4.45 kN	350 lb 1.56 kN

Soil classification per ASTM D-2487/2488

© 2018 American Earth Anchors
QR-PE36 Mar 2018



American Earth Anchors
info@americanearthanchors.com
americanearthanchors.com

Contact us for CUSTOM WORK
Size, length, shape, material,
prototypes, cable assemblies



866-520-8511



+1 508-520-8511

PE36

Installation

Through asphalt

Drill PILOT HOLE through asphalt

Diameter: 2" (5 cm)

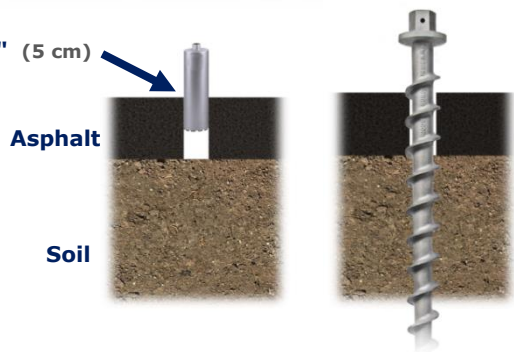

Installation methods

(Images show PE46, but method is the same)



Impact wrench

Watch the video: Click [here](#) or visit aeavideo.com



Power take-off

Watch the video: Click [here](#) or visit aeavideo.com

Attachment accessories



TIE-OFF CABLE PE-TC46



Can be doubled over to make large loop around structural member

4x4 lumber 3 1/2" x 3 1/2" (9 cm x 9 cm)

BRACKETS



For PIPE legs



For SQUARE legs



SLEEVES



Your 2 1/4" I.D. (58 mm) pipe fits over and rests on flange



We can make custom brackets - send us your requirements

